

# Quantifying Uncertainty Contributions For Fibre Optic Power Meter Calibrations

Author / Presenter: M Nel  
Co-Author: B Theron



*Your measure of excellence*

# Introduction

---

- Several uncertainty contributors
  - Calibration of fibre optic power meters
- Assign realistic magnitudes to uncertainty contributors
- Quantify the effect of:
  - Tightness of the fibre connector
  - Moving and flexing of fibre
- Conclusion



# Calibration setup and procedure

---

- Understand the uncertainty contributions in context
  - Calibration procedure
  - Measurement setup

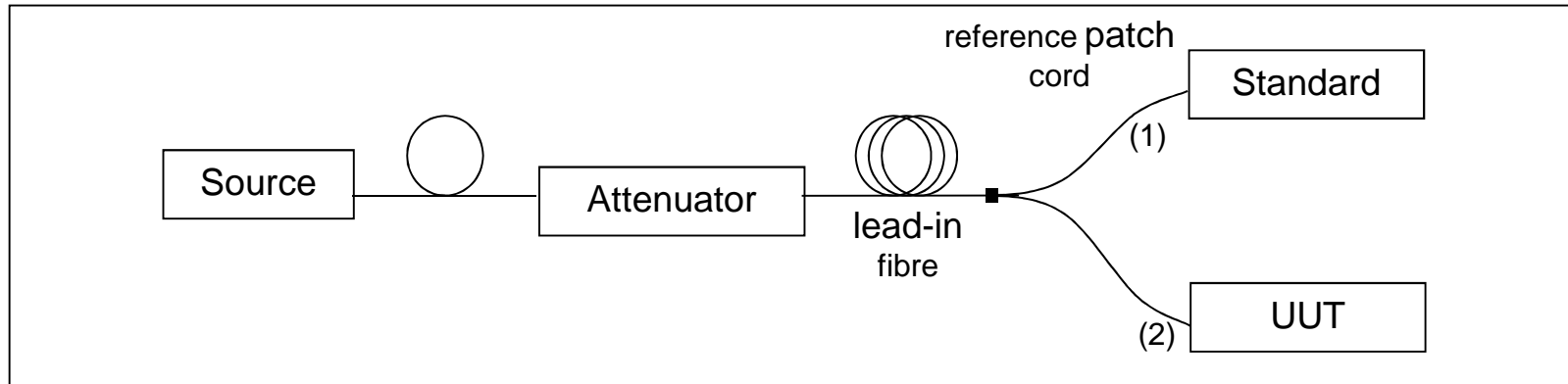

# Possible uncertainty contributors

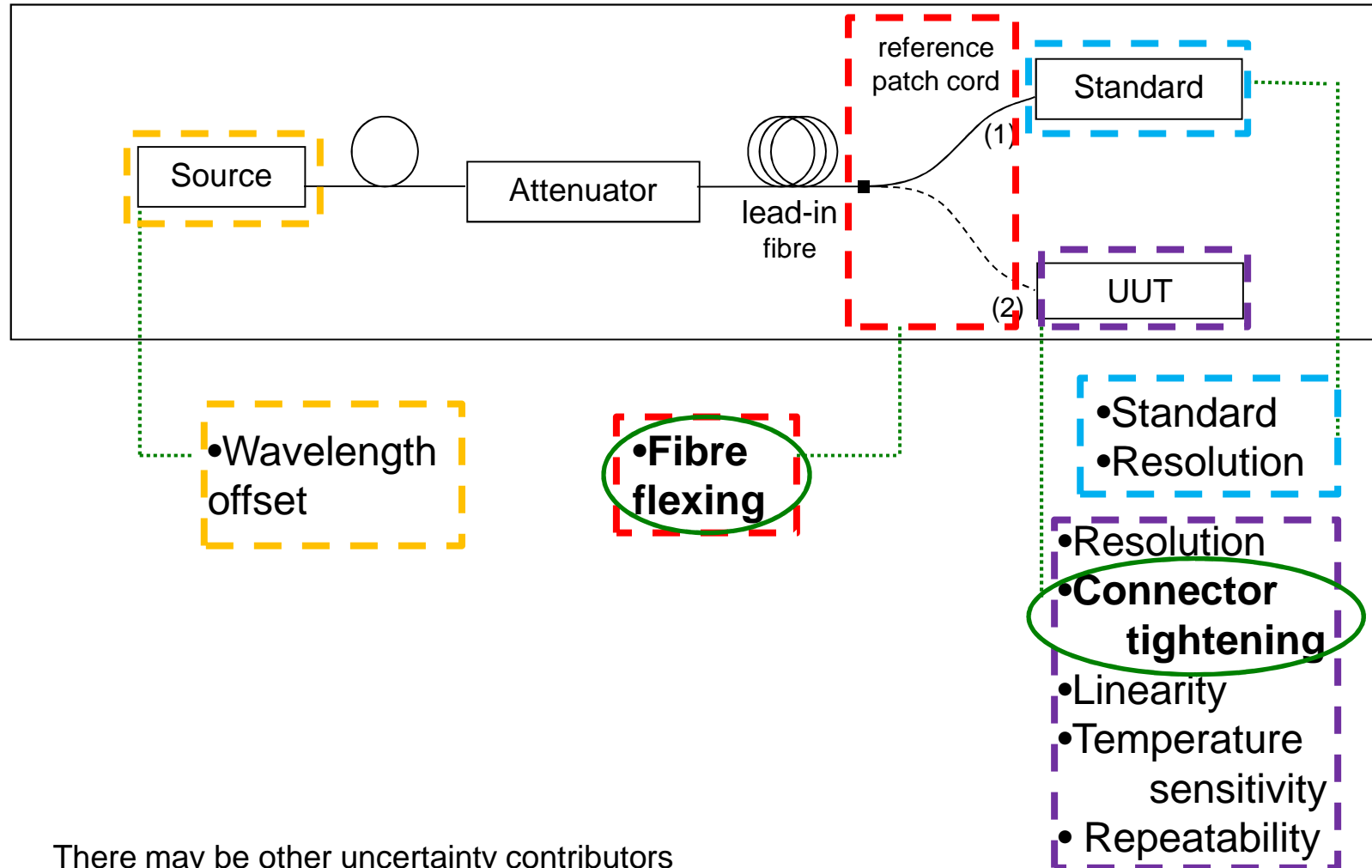

There may be other uncertainty contributors

# Method: Connector tightening effect

---

- Definitions

- “Un-tight”

- Tightened just so that the fibre does not move in the connector



- “Tight”

- Connector finger tightened but not forced



- 10 measurements were performed

- With no or minimal fibre flexing
  - Maximum difference between measurements as a % of total power measured

# Results: Connector tightening effect

---

<u>Wavelength [nm]</u>	<u>Uncertainty contribution [%]</u>
1 310 nm FP laser	0,012
1 550 nm FP laser	0,012

- Much higher contributions observed in the past
  - Depending on connector & adapter quality
- Reference patch cord – used for calibration
  - Dedicated end (connector)

# Results: Connector tightening effect

---

- Causes of the effect were not investigated:
  - Possible causes
    - Strain on the connector tip
    - Leading to micro bending & deformation
    - Influencing optical polarisation and reflections
- Connector tightening effects
  - May contain part of repeatability contribution
  - Better characterisation and understanding required
  - Considered to be appropriate as an independent contribution

# Method: Fibre flexing

---

- Effect of movement of the fibre during calibration

- Move optical head

- Rotation and displacement

- No reconnections of fibre

- Try to emulate only the effect of moving the fibre



- Definitions

- “Typical”

- displacement,  $d$ ,  $\pm 8$  cm

- “Extreme”

- Displacement,  $d$ ,  $\pm 15$  cm

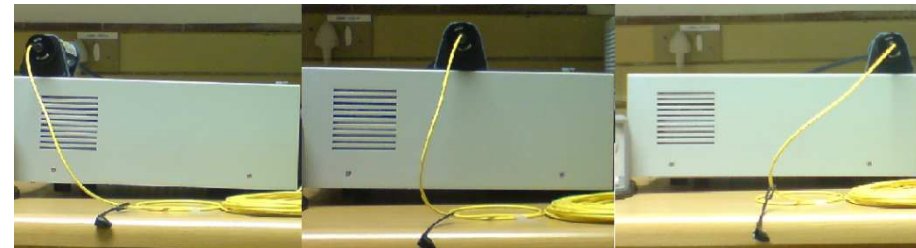
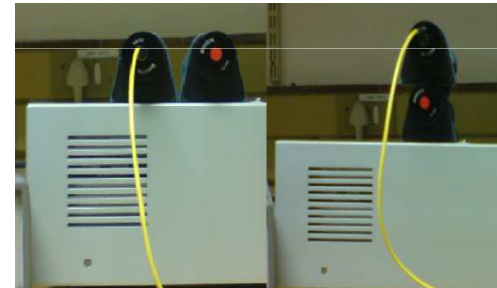

# Results: Fibre flexing

<u>Wavelength</u>	<u>Position</u>	<u>Uncertainty contribution [%]</u>
1310 nm FP laser	“Typical”	0,062
1310 nm FP laser	“Extreme”	0,105
1550 nm FP laser	“Typical”	0,052
1550 nm FP laser	“Extreme”	0,112

- “Extreme” – effect on power measurements increased drastically
- Excessive flexing and moving
  - May cause different radiant power reach or irradiate to
    - Standard and
    - Unit under test
  - Increase uncertainty of measurement

# Results: Fibre flexing

---

## Reduce the effect

- Place units side-by-side
- Optical axis parallel /  
Place keys in same position
- Use bend-insensitive fibre

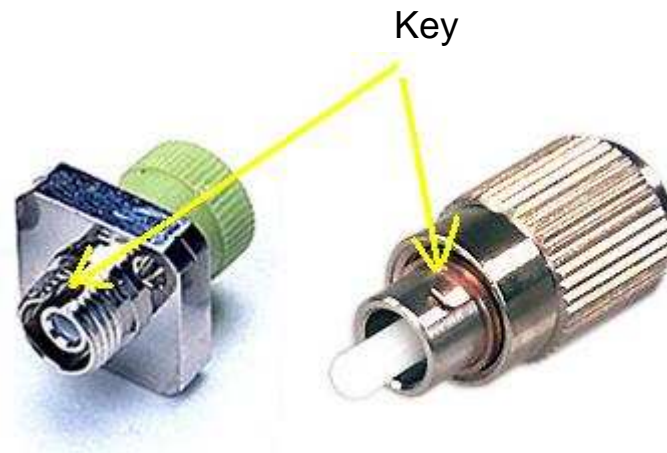
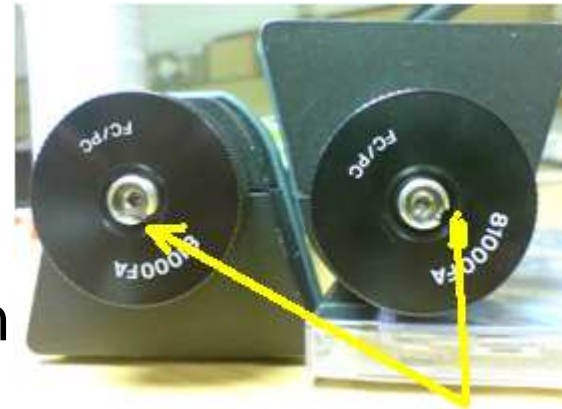

# Discussion and conclusion

---

- Looked at measurement setup and procedure
  - To determine uncertainty contributions
- Quantified uncertainty contributors
  - Connector tightening effect (FC connectors)
    - 0,012 % for 1310 nm and 1550 nm
  - Fibre flexing (standard single mode fibre)
    - 0,06 % to 0,12 % for 1310 nm and 1550 nm
- Current measurement capability
  - 1,5 % for Fibre optic power meters

# Discussion and conclusion

- Connector tightening effect may vary for different
  - Lasers
    - Depending on
      - Wavelength, Bandwidth, Mode dispersion, Coherence length
  - Optical heads
  - Optical fibres

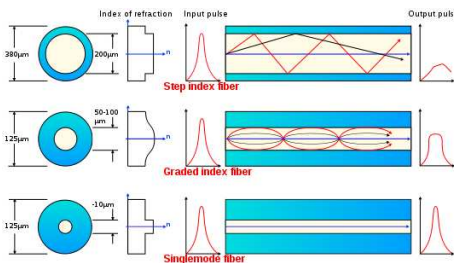

# Discussion and conclusion

- Connector tightening effect may vary for
  - Connector types
  - Connector end eg. metal or ceramic
  - Fibre tip and connector
    - Quality and manufacturing tolerances



# Discussion and conclusion

---

- Fibre flexing effect may vary
  - Wavelength, optical fibre etc.
  - Extent of bending during measurement
- Uncertainties can be reduced
  - Reference patch cord
  - eg. bend insensitive fibre
  - Limit fibre movement
- Important to quantify uncertainties for your own measurement setup



# Questions?

