

# Research @ the NMISA

Presented by:  
Sara Prins

*Your measure of excellence*



# Overview

- The NMISA
- The Research Portfolio
- NMISA 09/10 Research Projects
- The Road Ahead

# The NMISA

# NMISA: Mandate and Vision

## Mandate

to maintain the SI units and to **maintain and develop primary scientific standards of physical quantities** for SA and compare those standards with other national standards to ensure global measurement equivalence. It must also provide reference analysis in the case of a measurement dispute and maintain and develop primary methods for chemical analysis to certify reference materials for SA and the region

## Vision

to ensure that South Africa can prove measurement comparability and equivalence with the international community, in support of trade, in all national priority areas

# The NMISA Today

- Full membership of **8 (and 2/3) of the 10** Consultative Committees
- **470+ Calibration and Measurement Capabilities** accepted in the international measurement database
- NMISA is playing a **leading role** in SADC MET and now AFRIMETS
- Holds the secretariat for SADC MET, secretariat jointly with the National Regulator for AFRIMETS
- Holds the Chair of AFRIMETS

# The NMISA Today

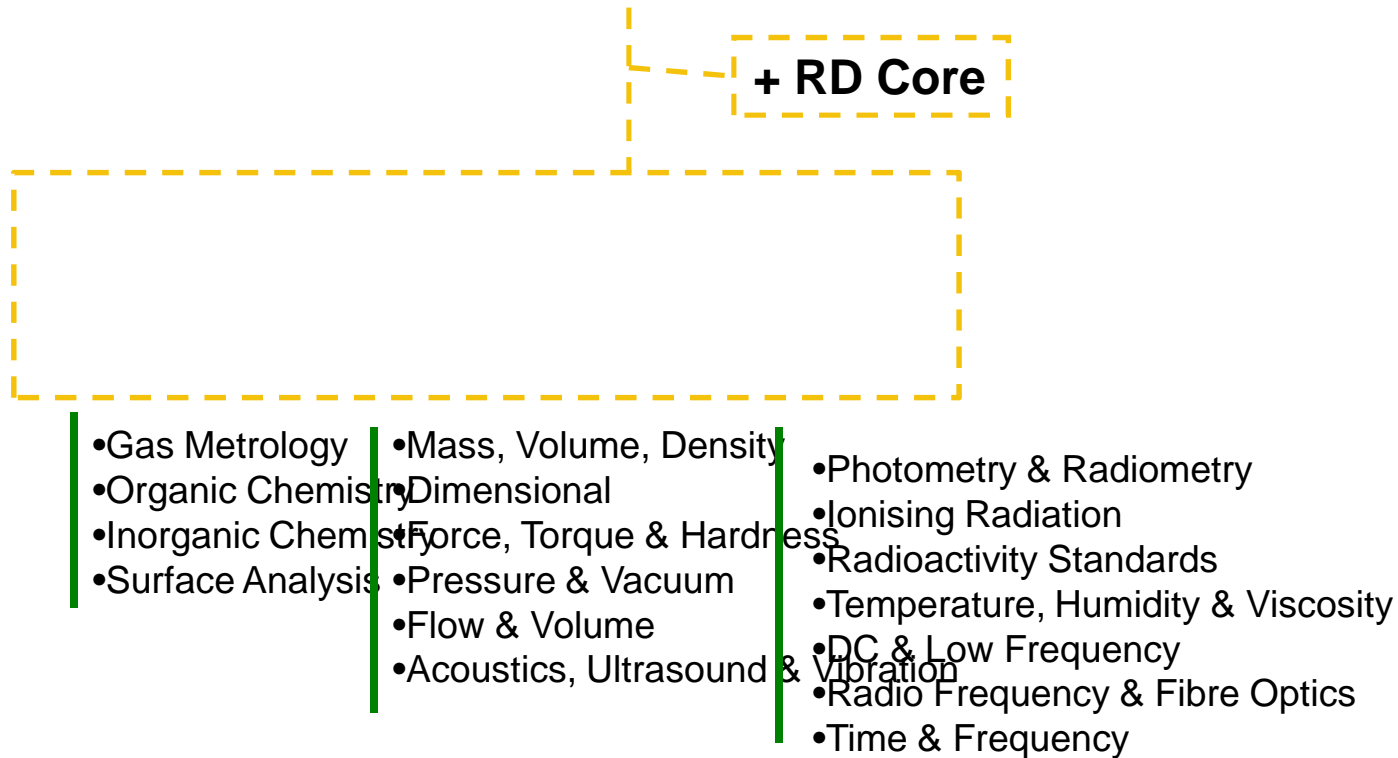

# The Research Portfolio

# Research Portfolio

- Established as 'independent' portfolio in 2007
  - Respond to emerging needs
  - Address critical needs
  - Long-term projects
- ~10% of the NMISA budget
- Objectives
  - Research infrastructure and support tools
  - Incubator for new ideas and NMS
  - Contribute to measurement science development
  - Coordination of external collaborative projects
  - Uplift international status and image of the NMISA

# Research Type Projects

- Fundamental Projects
  - Basic research
  - New knowledge generation
- Applied Projects
  - Measurement/Calibration need identified at TAF
  - Practical solutions serving the SA industry
- SADC/Africa Development Projects
  - Needs evaluation, training, PTs, comparisons
- Metrologist Skills Development Projects
  - Tapping into the dinosaurs!!
- Strategic Thrust Area Projects
  - Urgent emerging needs (dti, management)

# Research Project Outputs

- New NMS
- Reduced uncertainties on existing NMS
- New/Improved equipment set-ups
- Peer reviewed publications
- Skills development

# Research Administration

- Metrology Support
  - Statistical analysis interest group
  - Central software availability
  - Extended access to literature
  - Topic-interest speakers, eg Intellectual Property
- Technical Advisory Forums
  - Metrology area specific
- Liaisons
  - Other institutes
  - NRF
- Research Day
  - In-house day of research project proposals
  - NMISA Board and dti representation

# Overview of NMISA 09/10 Research Projects

# Research Projects 09/10

- Core Projects
  - Optical Frequency Standard
  - (Quantum Hall ‘resuscitation’)
- Metrology Area Projects
  - Trace water analysis in gas reference materials
  - Temperature scales
  - Mycotoxins
  - Elephantine Force
  - Coordinate Metrology
  - Nanotechnology
  - Nano-Energy

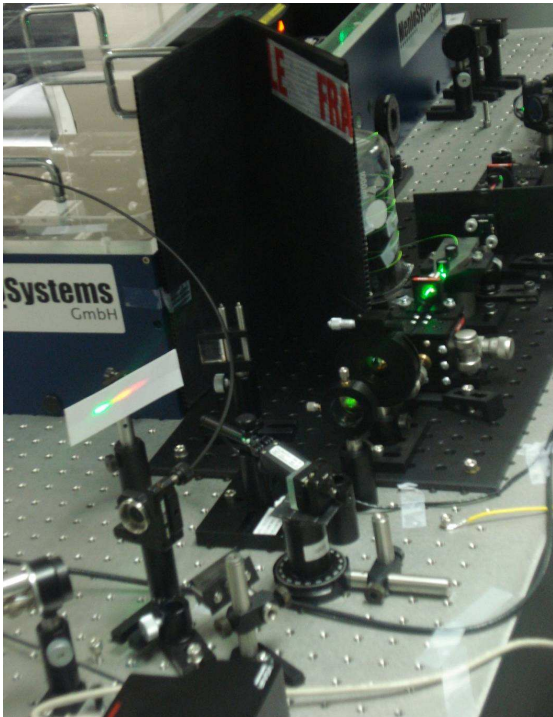

# Optical Frequency Standards

- Modern optical communications network
  - Measurements & calibrations in 1.3-1.6 $\mu\text{m}$  band
  - Reemergence of coherent communications (<MHz capability)<sup>†</sup>
- Dimensional
  - Manufacturing, Mining, Nanotechnology
- Chemical
  - Sensing & molecular spectroscopy
- Timing
  - Existing Cs standards
  - Space science (SKA, satellite industry)

# Optical Frequency Standard

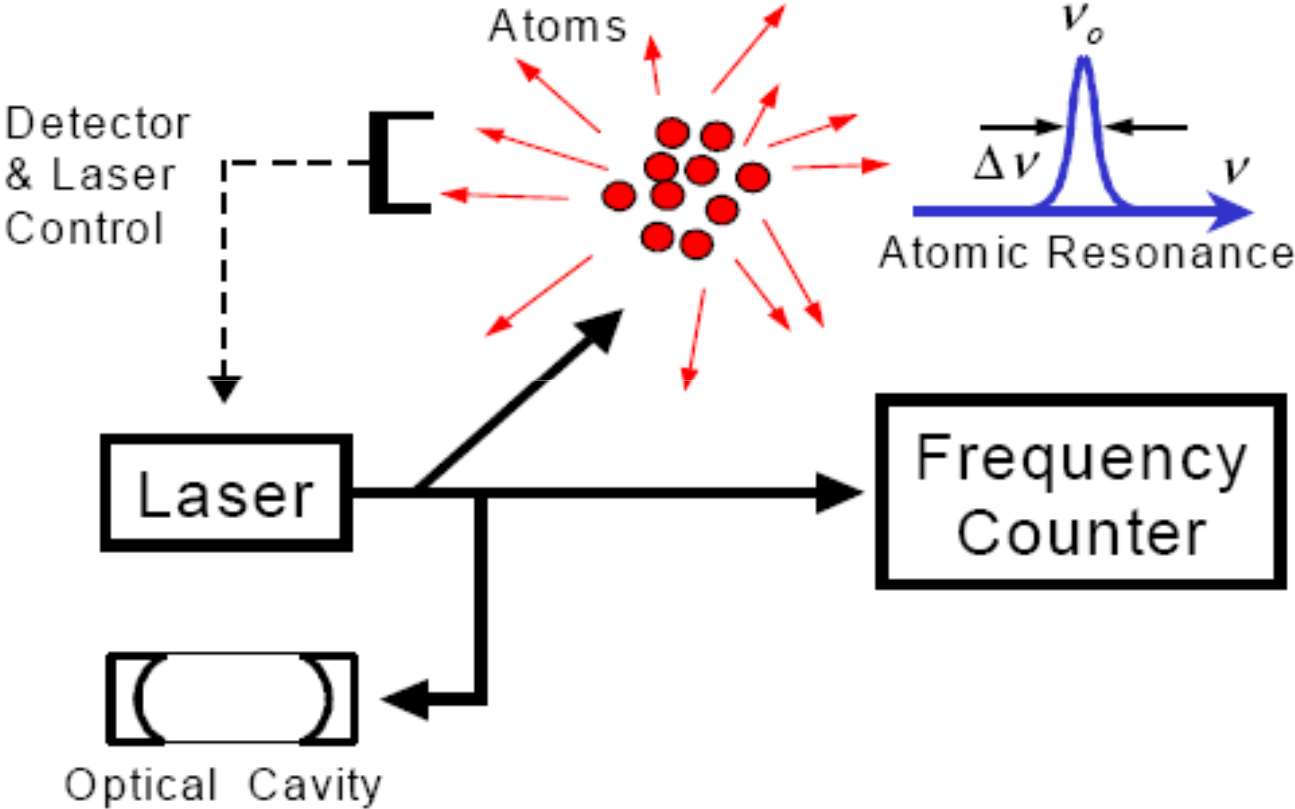



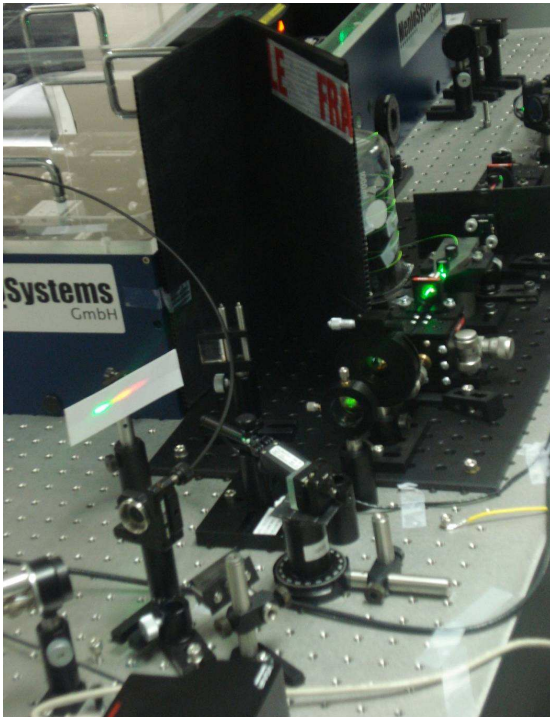

# System Control - Hardware

- Input sample rate: 400 million samples per second  
(14 bits = 16 384 divisions)
- Data transfer to output: 400 million samples per second  
(16 bits = 65 536 divisions)
- Temperature control
- Internal and external clock control

# Trace impurities in gas mixtures



Description	Use
Carbon monoxide (CO) in air/nitrogen	Ambient air monitoring
Carbon dioxide (CO <sub>2</sub> ) in air/nitrogen	Ambient air monitoring
Sulphur dioxide (SO <sub>2</sub> ) in air/nitrogen	Ambient air monitoring
Nitrogen monoxide (NO) in nitrogen	Ambient air monitoring
Nitrogen dioxide (NO <sub>2</sub> ) in air	Ambient air monitoring
Hydrogen Sulphide (H <sub>2</sub> S) in nitrogen	Ambient air monitoring

## Why analyse trace water in gas?

Corrosive gas mixtures

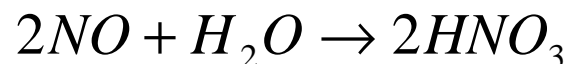
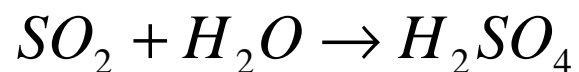

Impurity in nitrogen	Level (µmol/mol)
O <sub>2</sub>	<0.010
CO	<0.25
CO <sub>2</sub>	<0.25
H <sub>2</sub>	<1
H <sub>2</sub> O	<0.020
C <sub>n</sub> H <sub>m</sub> (as CH <sub>4</sub> )	<0.100

# Analysis of trace water in gas mixtures

CIMP-CCQM  
- GAWG -  
CMCs were not  
adequately  
supported by key  
comparisons, with  
the priorities for  
future work being  
identified as: argon;  
and trace levels of  
CO, H<sub>2</sub>, CH<sub>4</sub>, H<sub>2</sub>O,  
CO<sub>2</sub>, and C<sub>3</sub>H<sub>8</sub>.

- Project started in 2007
- Extensive training early 2008 at VSL (Netherlands)
- Procured commercial system mid-2008 for trace water analysis
- Next objective: link to the optical frequency project femtosecond laser to build a tunable laser for trace element analysis

# Fixed point cells

- Thermometry:
  - The accurate measurement of temperature is vital across a broad range of fields, including:
    - Industrial processes (e.g. making steel);
    - Manufacturing (e.g. glass products);
    - Monitoring (e.g. food transport and storage);
    - Health and safety (e.g. sterilisation of instruments).
  - In almost every sector, temperature is one of the key parameters to be measured.

# Temperature Scales

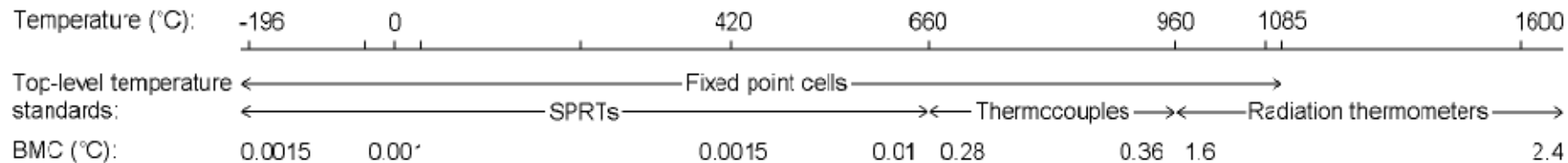

## Immediate benefit:

Greatly improved stability and long-term reproducibility (decades) of scale.

Facilitate preservation and reconstruction (if necessary) of scale.

## Future benefit:

Global efforts to reduce uncertainty of fixed point temperatures will allow reduction in uncertainty of local scale.

Develop a design for the primary spectral irradiance facility.

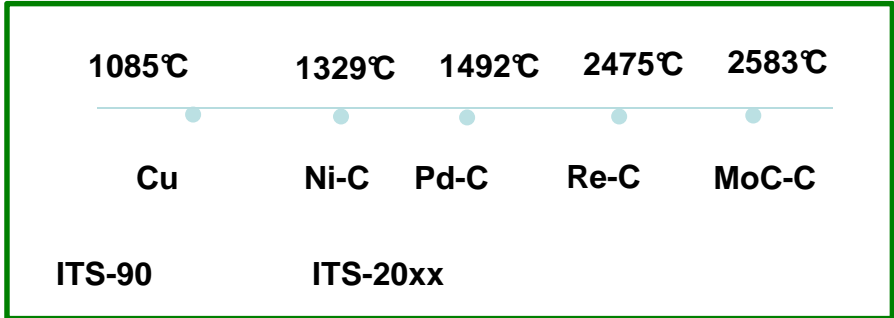

# Food Safety

## Mycotoxins

- Natural, secondary fungal metabolites
- Produced in the field or in storage
- **POTENT TOXINS:**  
cyto-, nephro- and neurotoxic,  
carcinogenic, mutagenic,  
immunosuppressive  
estrogenic effects

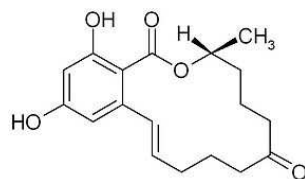
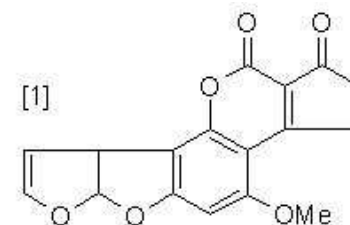
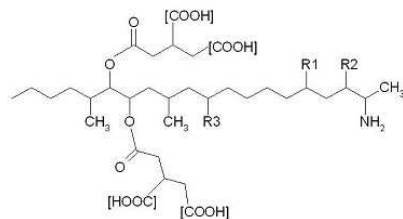
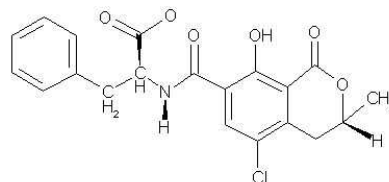

# Mycotoxin Regulations

- The *Codex Alimentarius* General standard for contaminants and toxins in food (2008) currently states maximum levels for the following:
  - Peanuts, almonds, hazelnuts and pistachios intended for further processing: not more than 15 µg/kg of aflatoxin (total);
  - “Ready-to-eat” almonds, hazelnuts and pistachios: not more than 10 µg/kg;
  - Milk: not more than 0.05 µg/l of aflatoxin M1;
  - Raw wheat, rye, and barley not more than 5 µg/kg; and
  - Apple juices and apple juice ingredients in other beverages: not more than 50 µg/l of patulin.

# Measuring mycotoxins

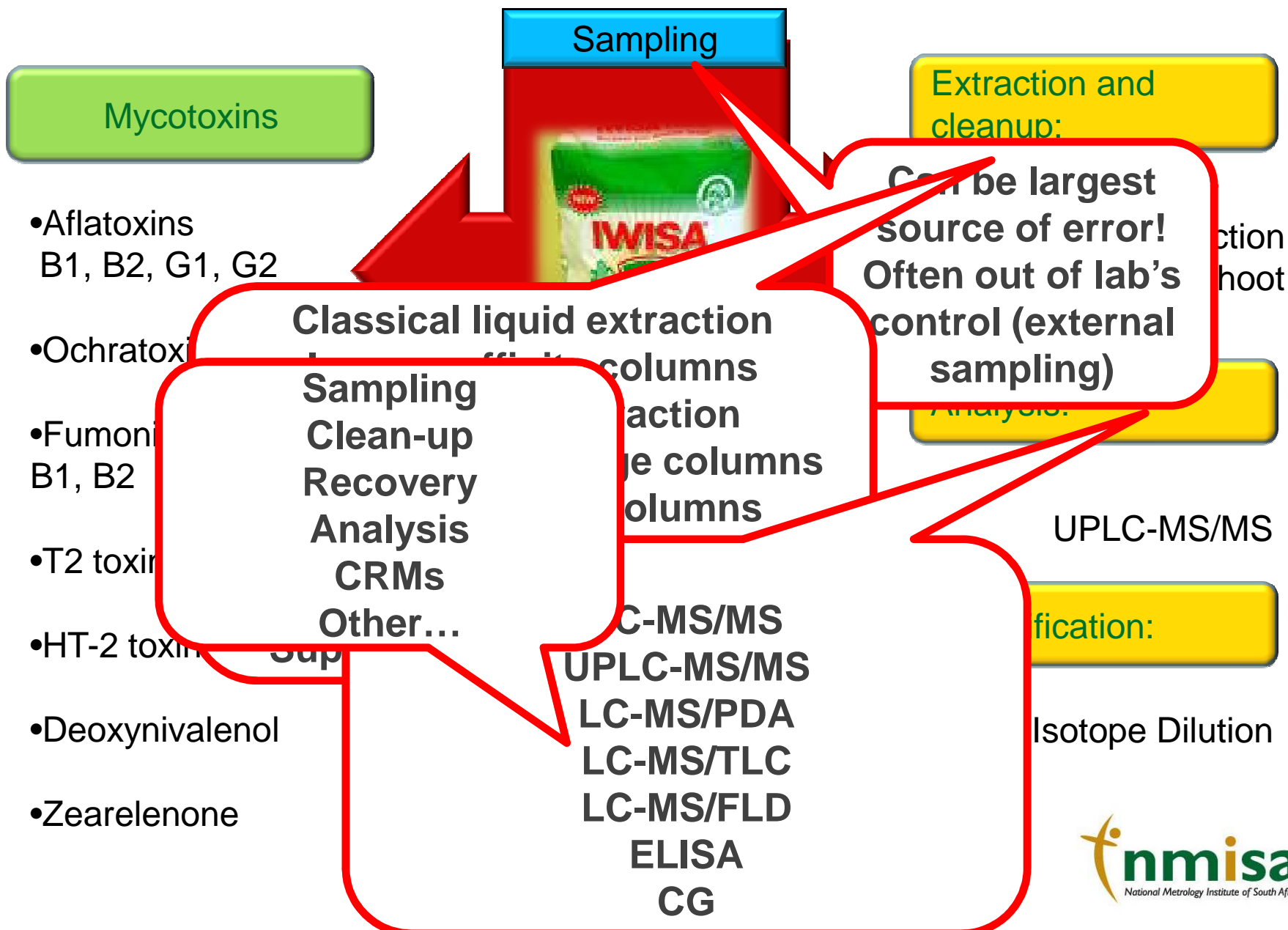

# Mycotoxin metrology

- Need to proof measurement equivalence to support international trade
- The range of mycotoxins all have different measurement challenges
  - Need for certified reference materials to validate analysis steps
  - Limited matrix CRMs are available
  - Calibration solutions
  - Reference methods / Equivalent methods
- Alternatives for SI traceability:
  - Spiked samples
  - Double isotope dilution MS with C-13 labeled isotopes

# Force Upgrade (The NMISA Dinosaur)



- 28 years old
- Electronics becoming obsolete
- Replacement costs ~R 80 mil
- Critical service to SA industry
  - Load cells
  - Tensile testing
  - Concrete testing

# Phase 1

***This project is to upgrade the existing KNICK AMPLIFIER electronics that handle the force hydraulic amplified machines. At present there is a problem with sourcing outdated electronic components. Keeping in mind that the electronic systems were designed in the early 1980's. Items such a germanium transistors are now obsolete. Thus no spare circuit boards can be obtained. The nature of this project would be that the KNICK amplifiers be replace with newer electronic control cards.***

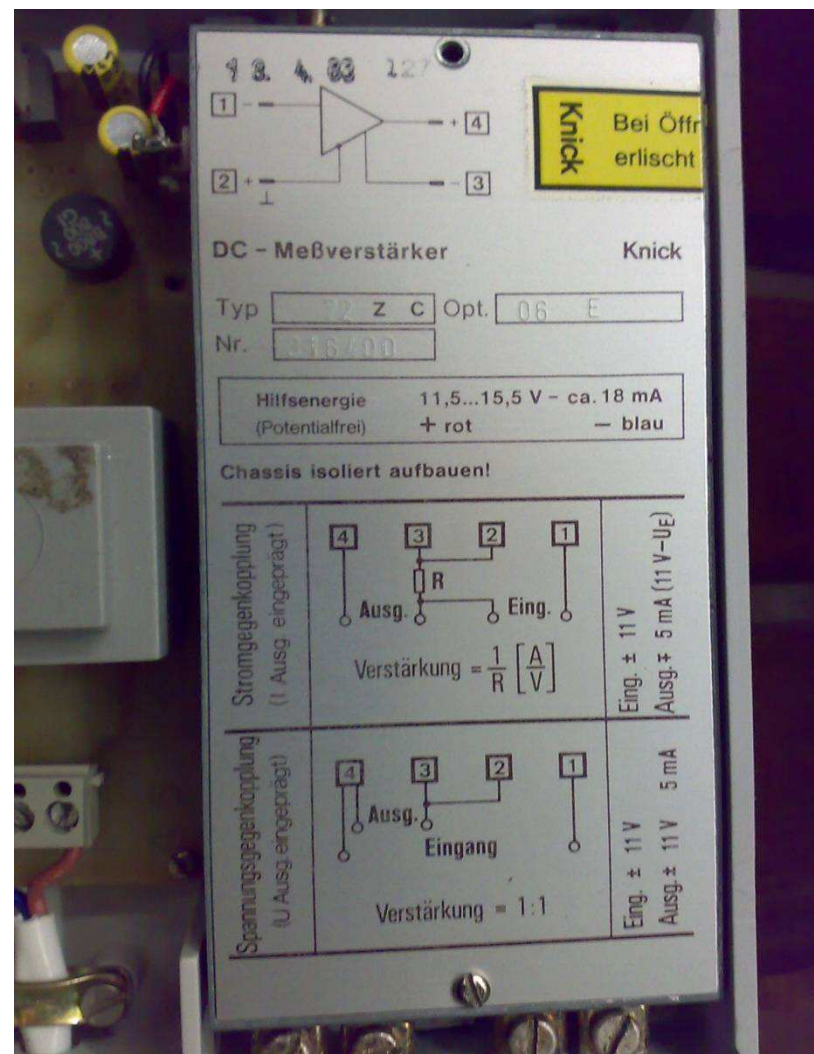

Also critical – the knowledge belong to a few dinosaurs, and it is important to transfer it to the new generation of metrologists so that NMISA can continue to serve the SA industry and its needs

# *BECAUSE THE WORLD IS NOT FLAT*

## *Coordinate metrology*

- 1) Large - laser trackers
- 2) Bridge / Gantry type
- 3) Scanners
- 4) Articulated Arms
- 5) Micro CMMs
- 6) Ultimate CMMs (Multilateration Laser)

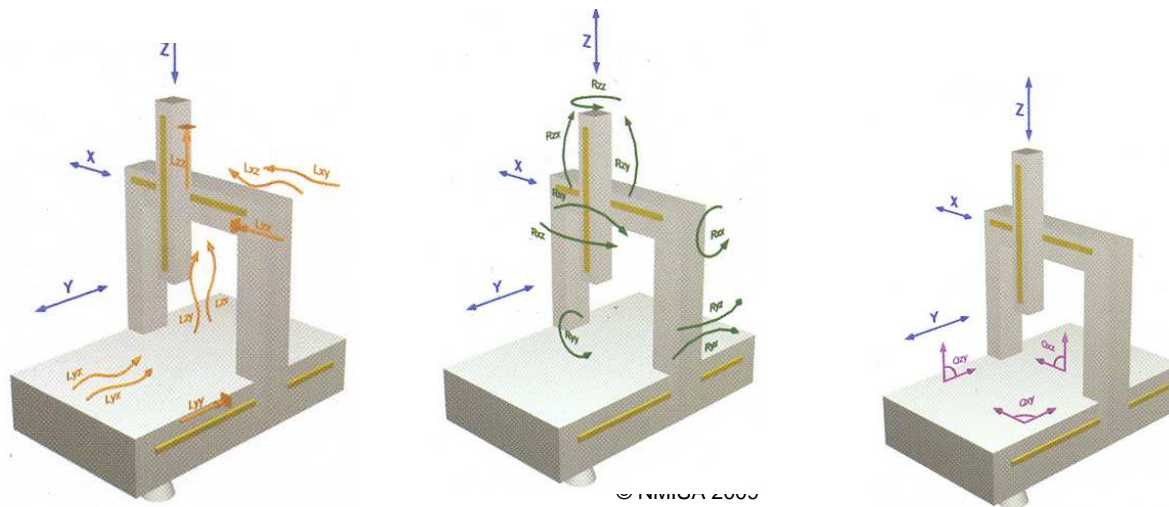

# Multilateration Laser tracker

- Collaborative project with University of Stellenbosch since 2007
- Full time student (M.Eng Mechatronics)
- Smaller uncertainty
- Shorter traceability chain

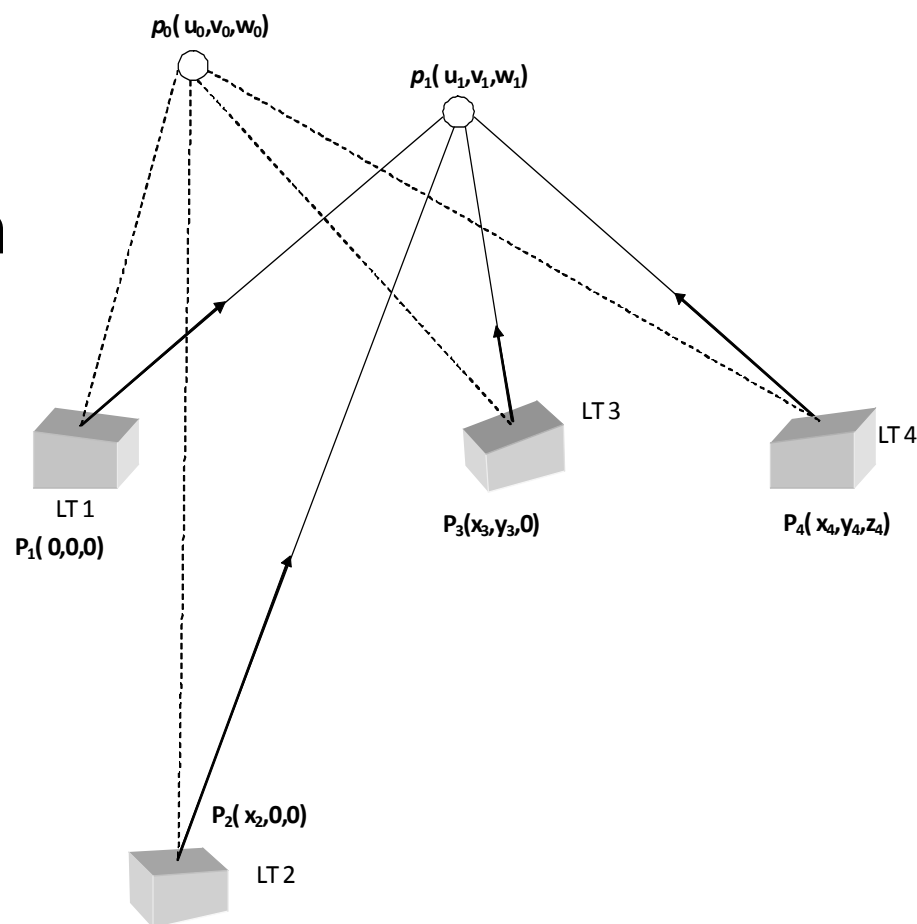

$$e_j = \sqrt{(x_j - X_i)^2 + (y_j - Y_i)^2 + (z_j - Z_i)^2 + (l_{ij} - L_i)}$$

# Nanotechnology

- Rules of physics at the nano scale is different
- The measurement challenges are greater, as only after the discovery of the nano-object/structure, one needs to measure
- The nano object itself, and the nano object in assembled form are two different measurements

# Nanoparticles

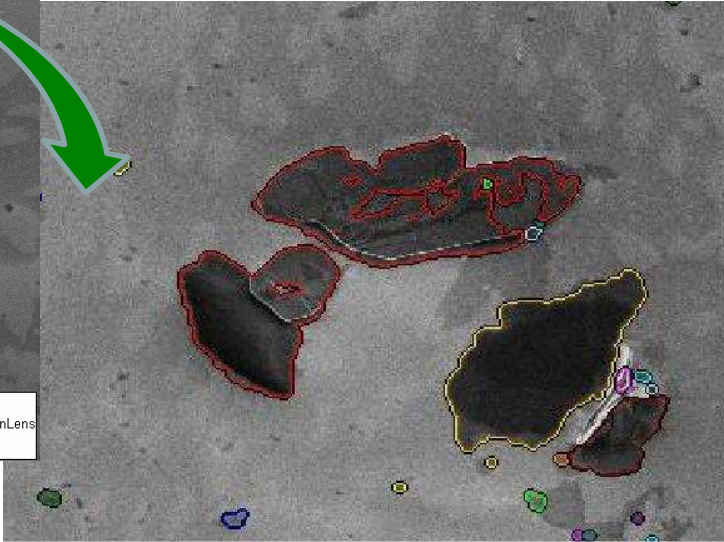
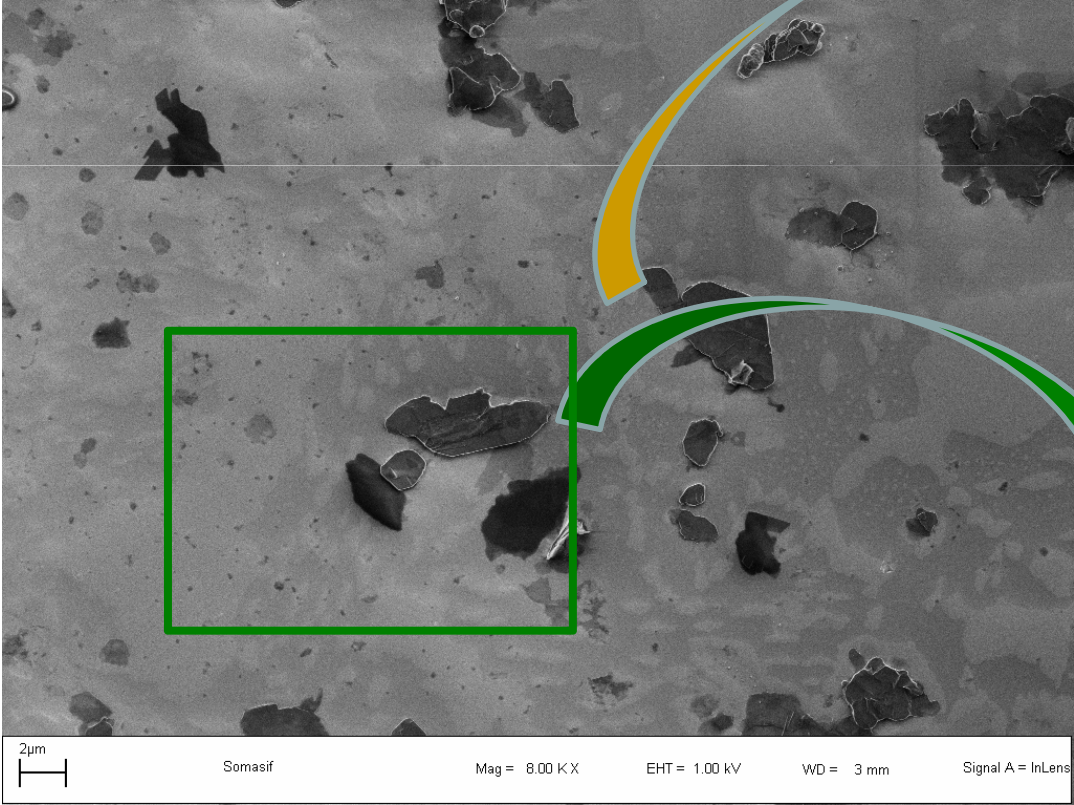
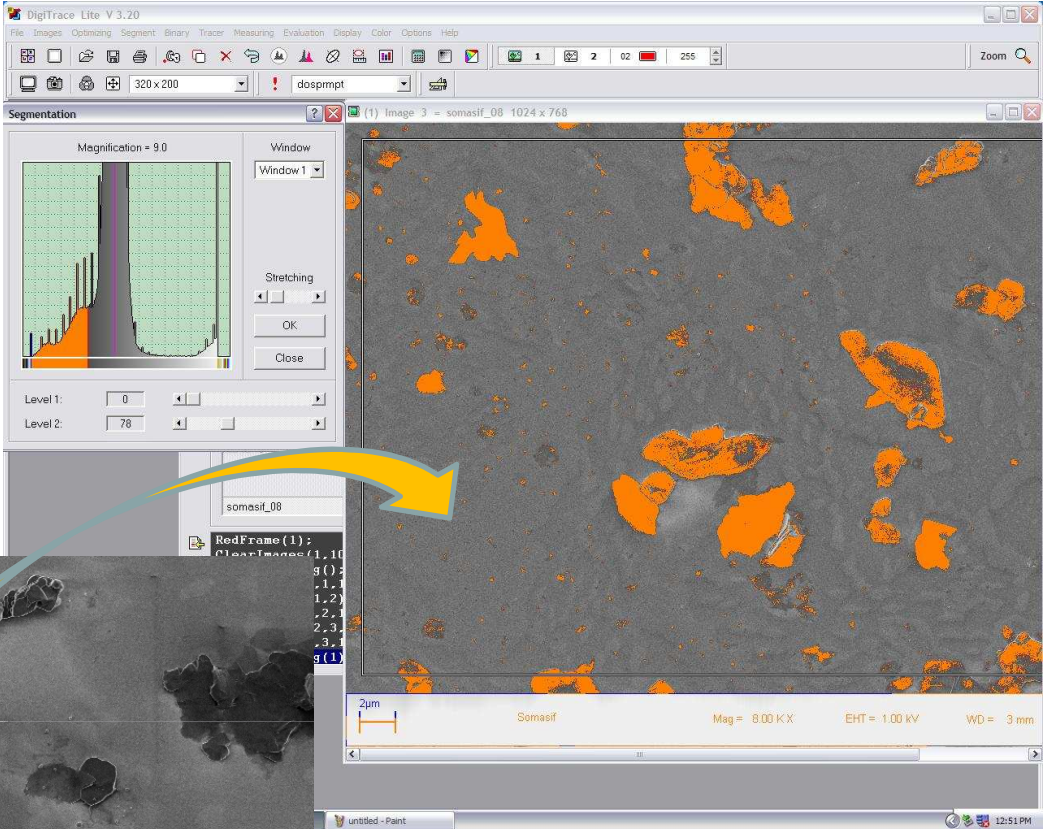

# Nano-dimensional metrology

The main objective of the nanometrology project is to provide **accurate and traceable dimensional measurements** for Nanotechnology initiatives in the country.

Conformity standards  
such as ISO TC 229

Reference standards such as

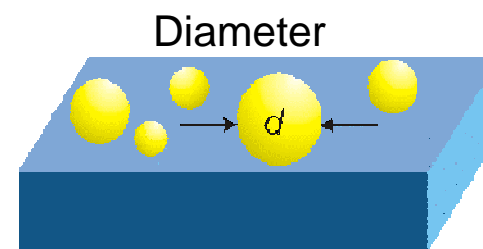
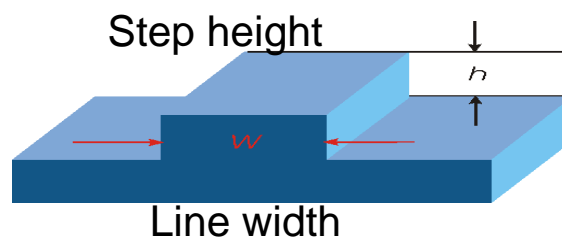
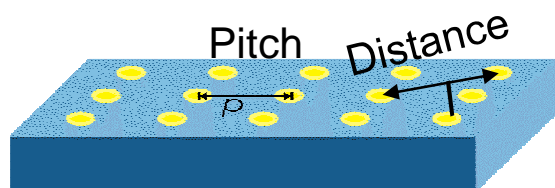

# Nano-dimensional metrology

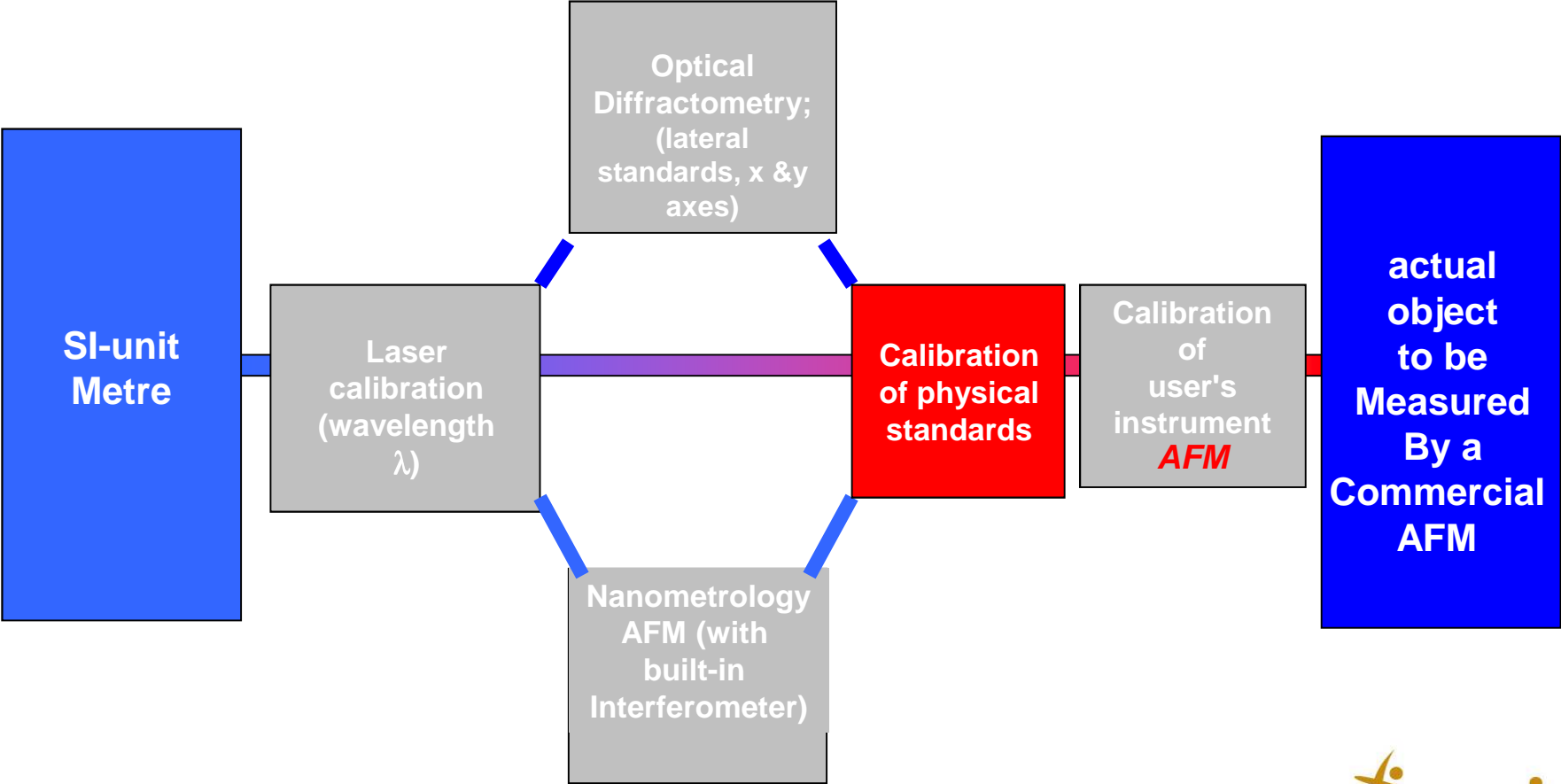

# Nano-Energy

- Fossil fuel sources are depleting at an alarming rate, global warming is accelerating through emissions from these fuels
- Solar energy is a good clean source of alternative energy
- Si forms basis of electronic industry, also good for photovoltaics
- Different forms of Si: a-Si, nc-Si,  $\mu$ c-Si, pc-Si, c-Si
- nc-Si for photovoltaics has tuneable optical properties and better stability

# Nano-Energy: Thin films of nc-Si:H

## ❖ Pros

- ❖ Tunable optical band gap
- ❖ Better stability
- ❖ Increased conductivity
- ❖ Low cost synthesis

Unique pros due to quantum confinement effect

## ❖ Cons:

- ❖ Extremely difficult to repeatedly synthesize material at the transition phase
- ❖ Mismatch in the absorption wavelengths of nc-Si:H and the solar spectrum

Incomplete understanding of the structural-property relationship of nc-Si:H

# The Road Ahead

# Future Plans for NMISA Research

- Technical Advisory Forums
  - Theme specific, eg wine industry, construction sector
  - Linked with NMISA Board's Technical Committee and Advisory Panel
- Research Day
  - Open to external stakeholders
  - Industrial representation on review panel
- Additional scope (?)
  - 'applied' projects to support development of measurement tools for industry and African development on a joint funding basis

# Thank you!

## Acknowledgments:

- To all the NMISA staff, especially those who submitted research proposals and participated in Research Day 09
- To our stakeholders, who come to us with their needs. We can only develop something for you if you tell us what you need
- The dti for funding